

Figure 3. T-4 and T-5 Wiring Before Modification

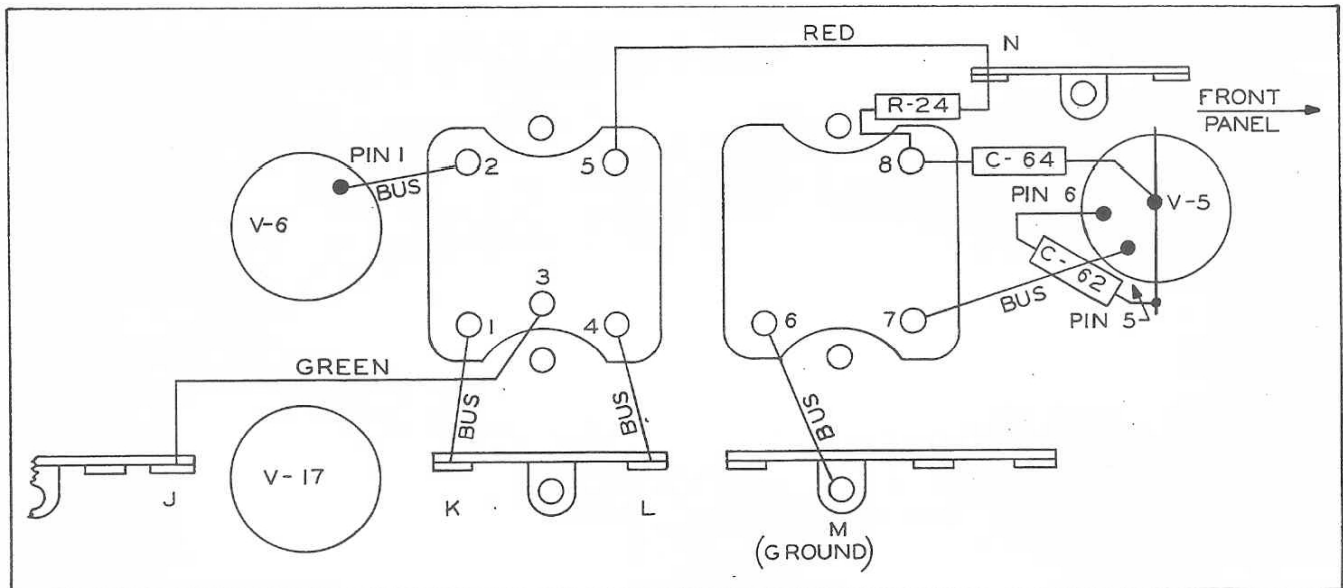

Figure 4. Mechanical Filter Adapter Wiring After Modification

switch arm is down toward the chassis as shown in figure 2, as it may be impossible to move it into position after the mechanical filter adapter is installed.

- 16. Attach the mechanical filter adapter to the chassis using the shake-proof washers and nuts that formerly held T-4 and T-5. Place a shake-proof washer and nut on each of the four lugs which extend through the chassis. Do not tighten the nuts until shaft alignment is assured.

- 17. Push the long quarter-inch tube through the front panel about one-half inch then slide the clamp with the five-sixteenths hole on the shaft followed by a one-fourth inch washer. Be sure the clamp is oriented as shown in figure 2.
- 18. Shove the shaft on through the gear panel to within an inch of the rear apron of the mechanical filter adapter.
- 19. Slide the other quarter-inch washer onto the